

Clarke®



DIGITAL CALIPER
MODEL NO: CM145
PART NO: 4500360

OPERATION & MAINTENANCE INSTRUCTIONS

UK
CA | CE



ORIGINAL INSTRUCTIONS

DL0623 - ISS 4

INTRODUCTION

Thank you for purchasing this CLARKE Digital Caliper.

Please read this instruction leaflet thoroughly and follow the instructions carefully, to ensure that the instrument will give you long and satisfactory service.

Please keep these instructions in a safe place for future reference.

GUARANTEE

This CLARKE product is guaranteed against faulty manufacture for a period of 12 months from the date of purchase. Please keep your receipt as proof of purchase.

This guarantee is invalid if the product is found to have been abused or tampered with in any way, or not used for the purpose for which it was intended.

Faulty goods should be returned to their place of purchase, no product can be returned to us without prior permission.

This guarantee does not effect your statutory rights.

SAFETY PRECAUTIONS

- Keep the body of the caliper clean at all times, do not use alcohol or other corrosive chemicals as they could damage the internal electronics.
- Prevent accidental damage to the caliper by storing in its case when not in use.
- DO NOT immerse the caliper in liquid or allow liquid to enter the slide.

GENERAL VIEW

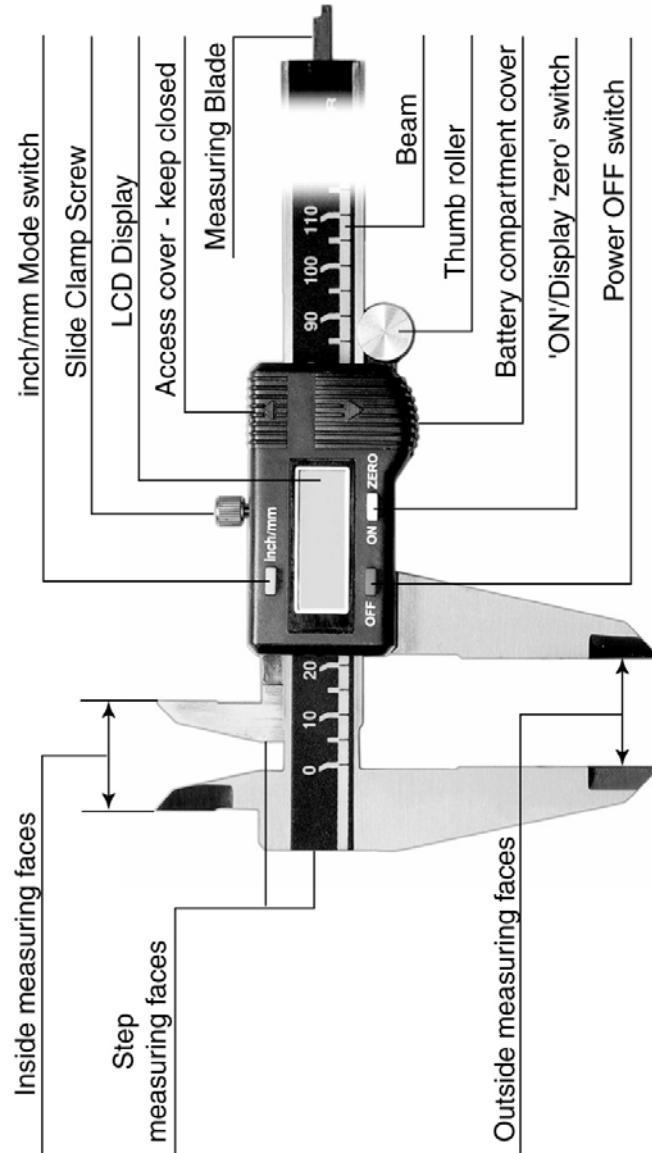

BATTERY REPLACEMENT

When the display constantly flashes the battery requires replacement.

Slide off the battery compartment cover and insert a new battery with the positive (+) side facing up.

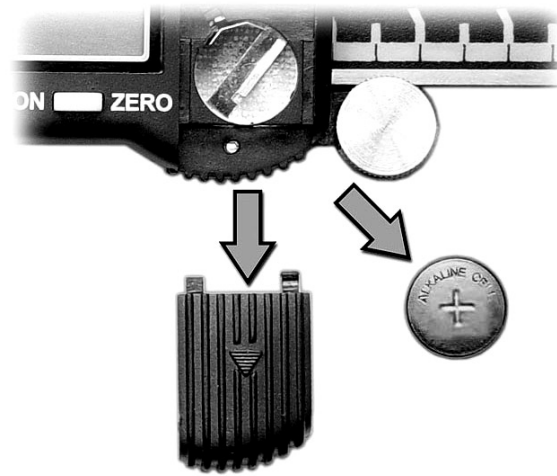

SETUP AND OPERATION

- Loosen the slide clamp screw.
- Press the ON button to switch the calipers on, select the required measuring unit by pressing the inch/mm mode switch.

ZERO YOUR CALIPERS

It's critical to zero your calipers before taking any measurements. If you skip this step, your subsequent measurements may not be accurate.

1. Close the calipers fully.
2. Press the ON/Zero button to set it to zero. The display reads 0.000"

MEASURING OUTSIDE DIMENSIONS

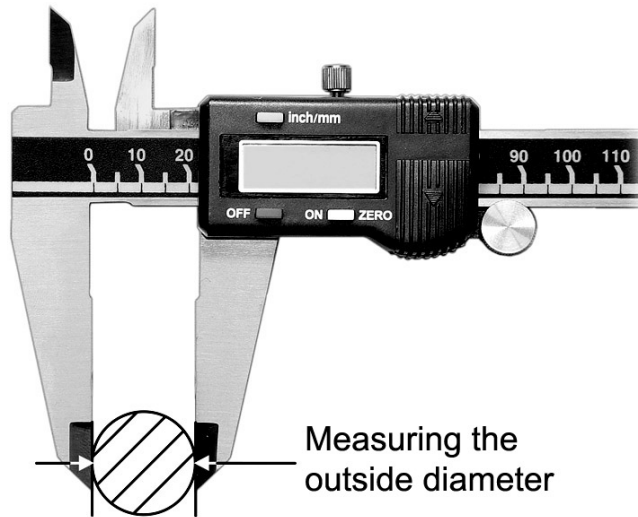

You can also use the outside jaws to measure the thickness of an object.

Make sure the object is perpendicular to the jaws so the measurement is accurate.

MEASURING INSIDE DIMENSIONS

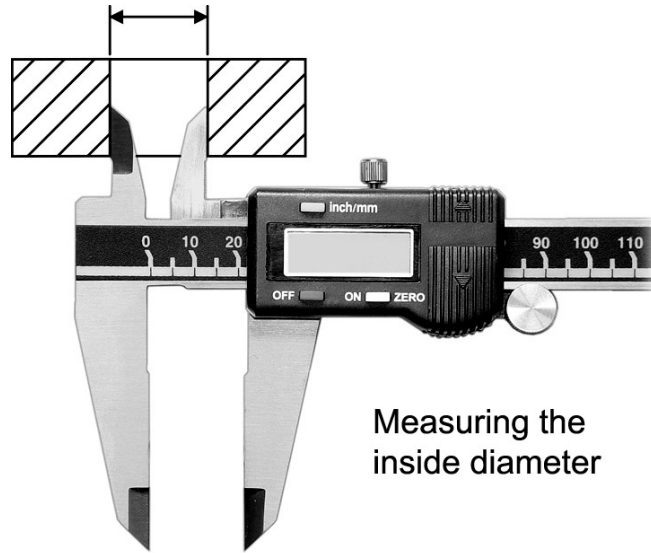

Measuring the
inside diameter

Use the inside jaws to measure the inside dimensions of an object.

Make sure the object is perpendicular to the jaws so the measurement is accurate.

MEASURING DEPTH

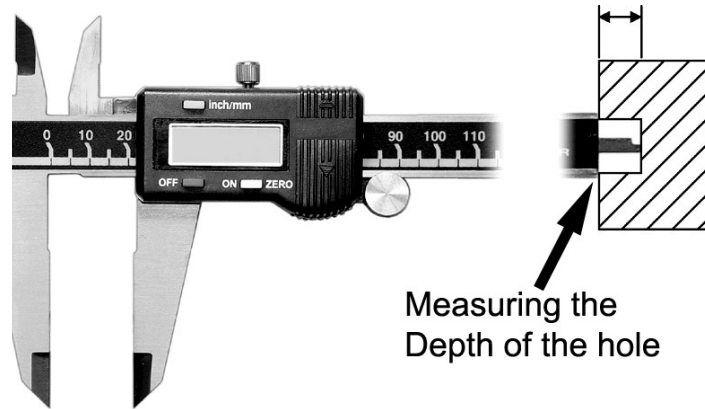

Use the depth gauge to measure the depth from one surface to the next.

Make sure the calipers are perpendicular to the surface being measured so the measurement is accurate.

TAKING A STEP MEASUREMENT

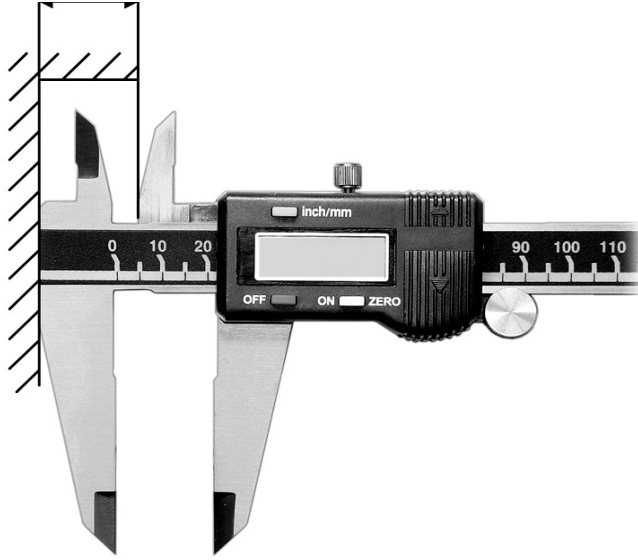

Use the step gauge to measure the distance between one edge and the next edge above it

TAKING A COMPARATIVE MEASUREMENT

EXAMPLE: You need to find the difference between the diameter of a hole and the diameter of the cylinder that fits into the hole.

1. Close the calipers.
2. Press the ON/Zero button to zero your calipers.
3. Take an outside measurement of the cylinder.
4. Carefully remove the cylinder without disturbing the caliper.
5. Press the ON/Zero button to zero your calipers.
6. Take a inside measurement of the hole.
7. The value shown is the difference.

SELECTING METRIC/IMPERIAL

Press the MM/INCH button to switch between metric and imperial measurement values.

TROUBLESHOOTING

FAULT	CAUSE/SOLUTION
Display flashes constantly.	Low battery - Replace battery.
Display fails to change when slider is moved.	Electronic fault - Remove battery & re-insert after 30 seconds.
Display fails to function.	Battery flat or in poor contact - Re-insert or replace battery.
Measuring becomes less accurate.	Dirty sensor - Clean caliper thoroughly with compressed air.

SPECIFICATIONS

Measuring Range	0 mm - 150 mm
Measuring Scale	0.01 mm / 0.005"
Accuracy (0 mm -150 mm)	0.03 mm
Operating Temperature Range	-10°C to 40°C
Battery Type & Voltage	Alkaline Cell (LR44) 1.55 Volt

A SELECTION FROM THE VAST RANGE OF

Clarke®
QUALITY PRODUCTS



AIR COMPRESSORS
From DIY to industrial. Plus air tools, spray guns and accessories.

GENERATORS
Prime duty or emergency standby for business, home and leisure.

POWER WASHERS
Hot and cold, electric and engine driven - we have what you need

WELDERS
Mig, Arc, Tig and Spot. From DIY to auto/industrial.

METALWORKING
Drills, grinders and saws for DIY and professional use.

WOODWORKING
Saws, sanders, lathes, mortisers and dust extraction.

HYDRAULICS
Cranes, body repair kits, transmission jacks for all types of workshop use.

WATER PUMPS
Submersible, electric and engine driven for DIY, agriculture and industry.

POWERTOOLS
Angle grinders, cordless drill sets, saws and sanders.

STARTERS/CHARGERS
All sizes for car and commercial use.

**PARTS & SERVICE:
0208 988 7400**

Parts Enquiries
Parts@clarkeinternational.com

Servicing & Technical Enquiries
Service@clarkeinternational.com

SALES: UK 01992 565333 or Export 00 44 (0)1992 565335

Clarke INTERNATIONAL Hemnall Street, Epping, Essex CM16 4LG
www.clarkeinternational.com